

Modèle probabiliste de comportement et algorithme d'apprentissage par imitation pour les personnages crédibles dans les jeux vidéo

Fabien Tencé
Soutenance de thèse



10 novembre 2011

Cadre et objectifs de la thèse

Objectifs

Crédibilité Imitation

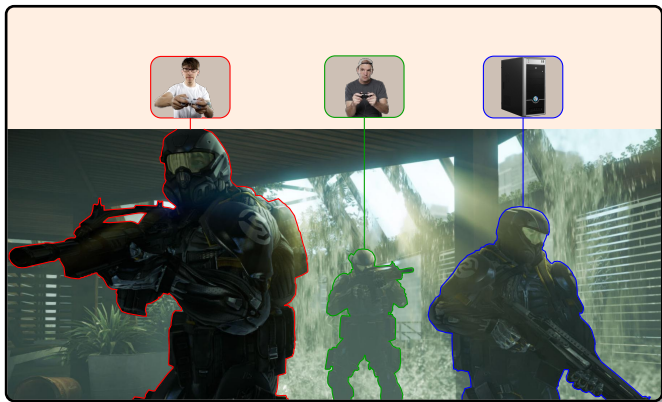

[Livingstone, 2006][Thureau et al., 2005]

Cadre et objectifs de la thèse

Objectifs

Crédibilité Imitation

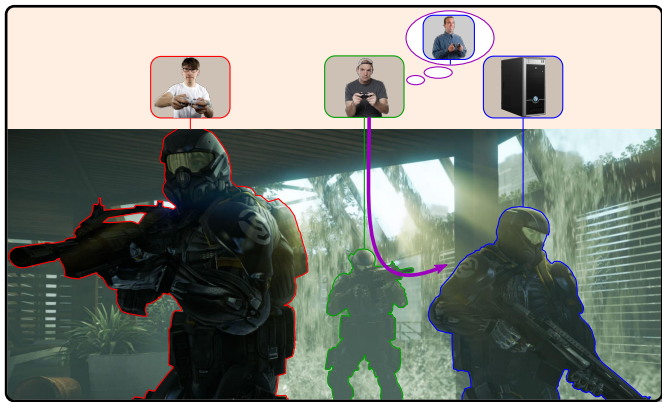

[Livingstone, 2006][Thureau et al., 2005]

Cadre et objectifs de la thèse

Objectifs

Crédibilité Imitation

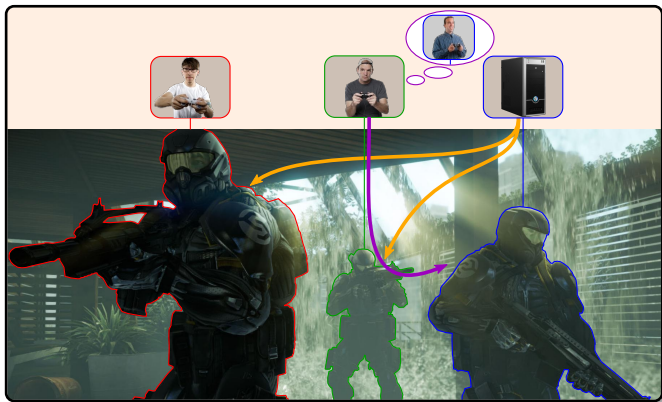

[Livingstone, 2006][Thureau et al., 2005]

Chameleon

Objectifs

Crédibilité Imitation

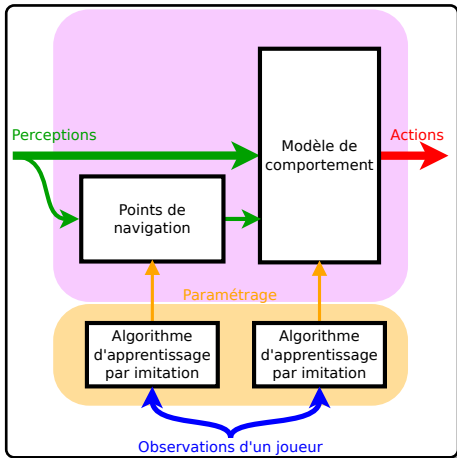

Plan

- 1 Introduction
- 2 État de l'art
- 3 Points de navigation
- 4 Modèle de comportement
- 5 Conclusion

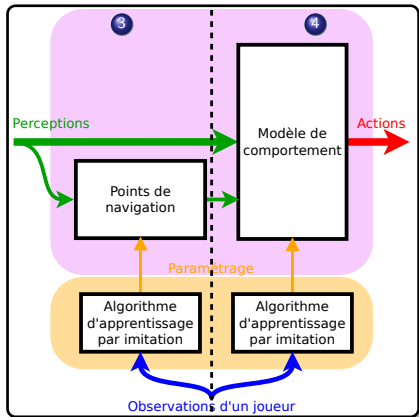

Plan

- 1 Introduction
- 2 État de l'art**
- 3 Points de navigation
- 4 Modèle de comportement
- 5 Conclusion

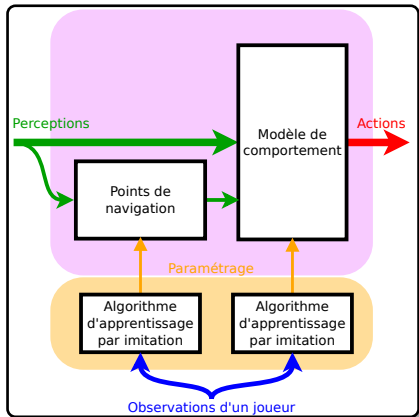

4 types de solutions

Connexionniste

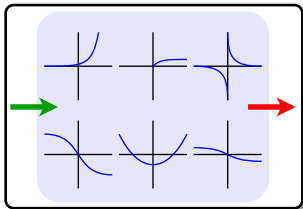

États-Transitions

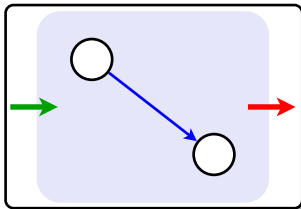

Système de production

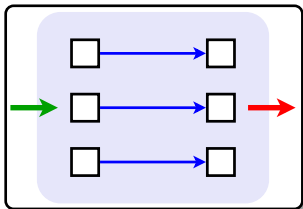

Probabiliste

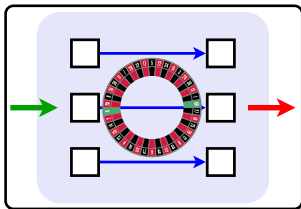

4 types de solutions

Connexionniste

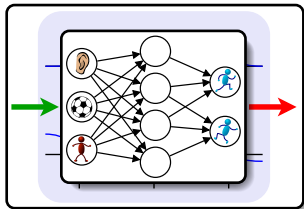

États-Transitions

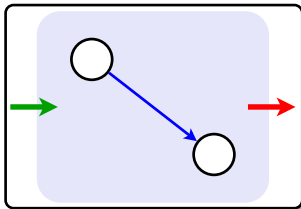

Système de production

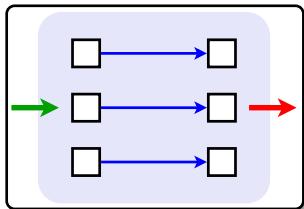

Probabiliste

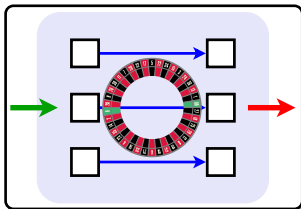

4 types de solutions

Connexionniste

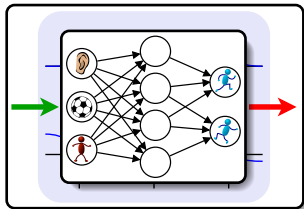

États-Transitions

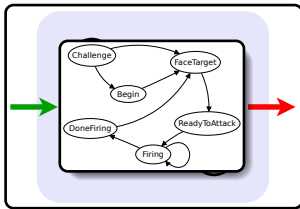

Système de production

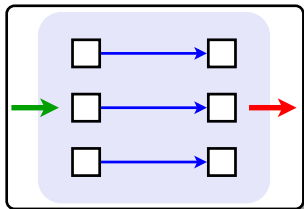

Probabiliste

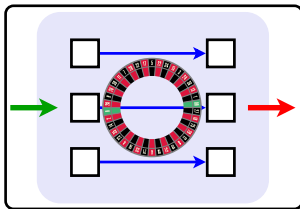

4 types de solutions

Connexionniste

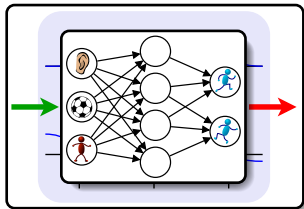

États-Transitions

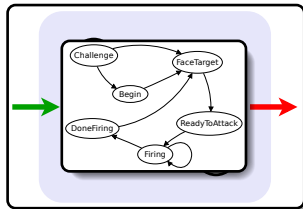

Systeme de production

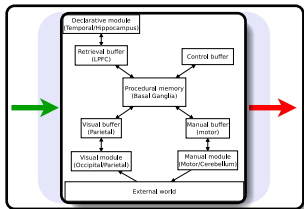

Probabiliste

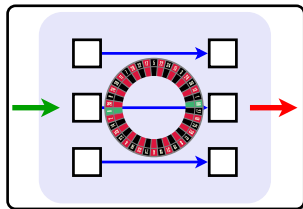

4 types de solutions

Connexionniste

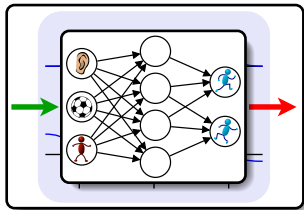

États-Transitions

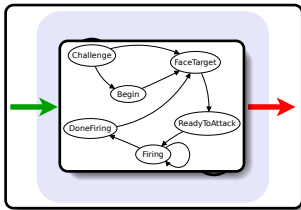

Système de production

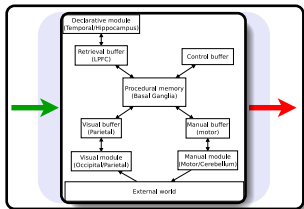

Probabiliste

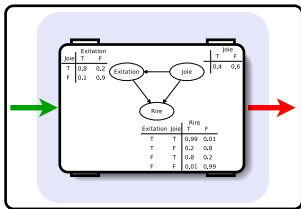

4 types de solutions

Connexionniste

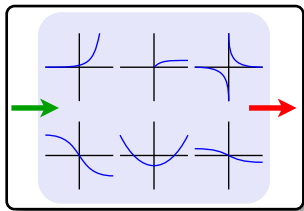

États-Transitions

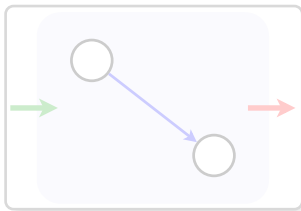

Système de production

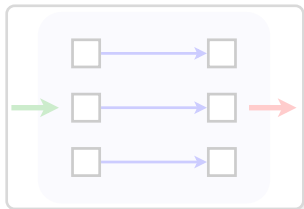

Probabiliste

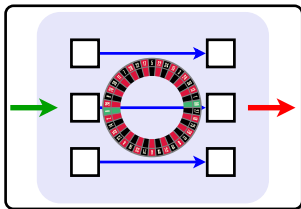

Approches utilisées

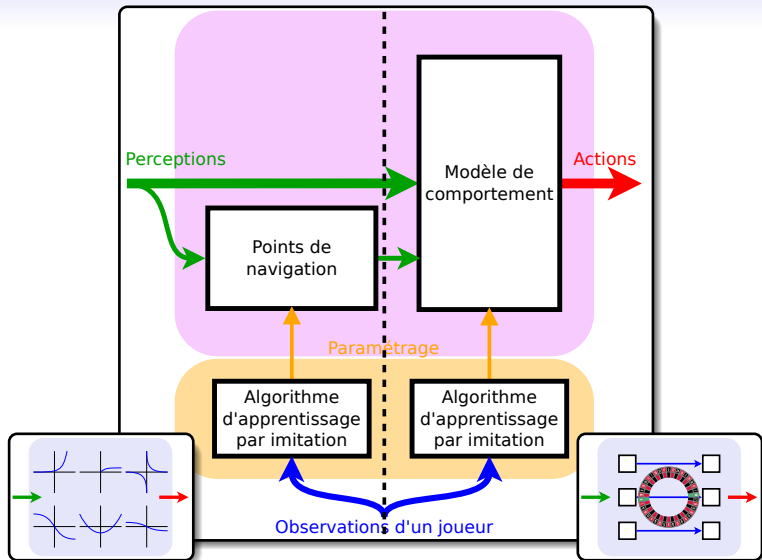

Approches utilisées

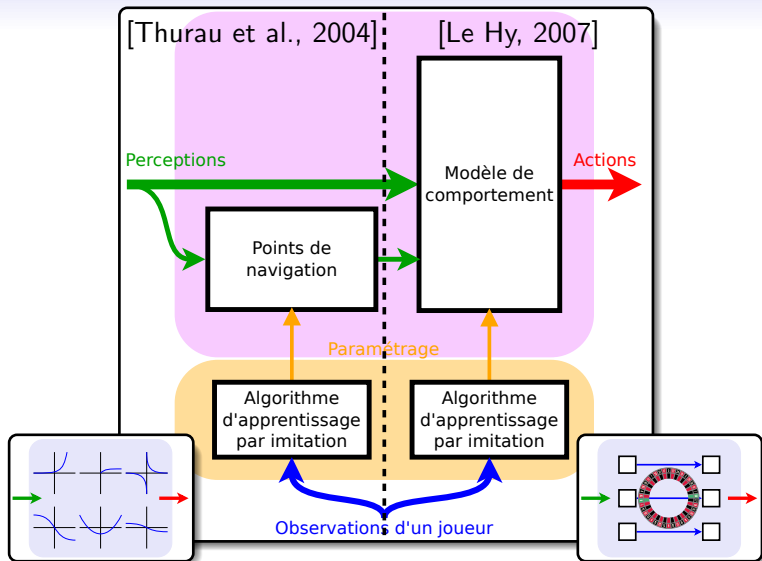

Plan

- 1 Introduction
- 2 État de l'art
- 3 Points de navigation**
- 4 Modèle de comportement
- 5 Conclusion

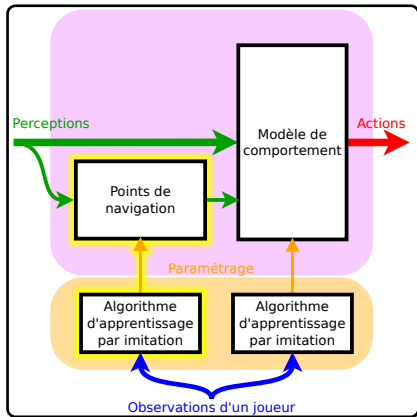

Représentation de l'environnement

Objectif :
Apprentissage

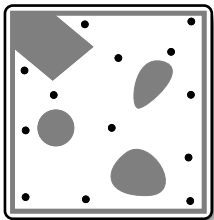

[Thureau et al., 2004]
GNG [Fritzke, 1995]



Limite du GNG

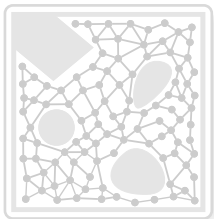

SGNG [Tencé et al., 2010b]

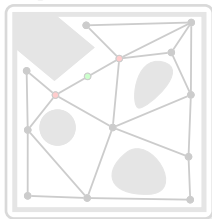

Représentation de l'environnement

Objectif :
Apprentissage

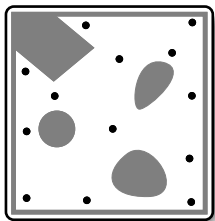

[Thureau et al., 2004]
GNG [Fritzke, 1995]

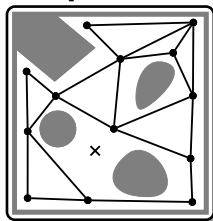

Limite du GNG

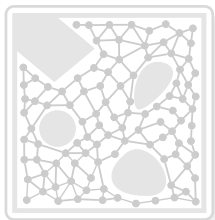

SGNG [Tencé et al., 2010b]

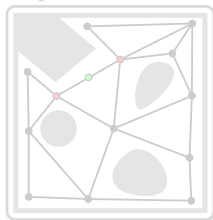

Représentation de l'environnement

Objectif :
Apprentissage

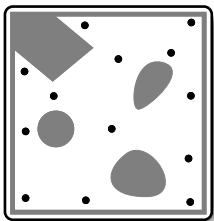

[Thureau et al., 2004]
GNG [Fritzke, 1995]

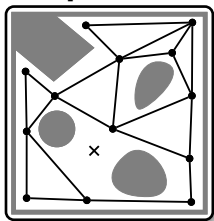

Limite du GNG

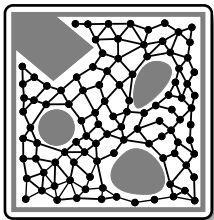

SGNG [Tencé et al., 2010b]

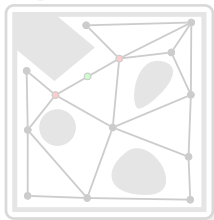

Représentation de l'environnement

Objectif :
Apprentissage

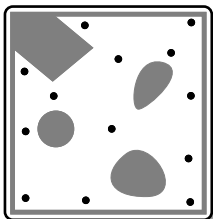

[Thureau et al., 2004]
GNG [Fritzke, 1995]

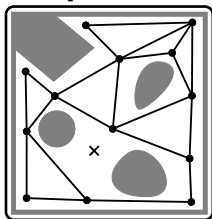

Limite du GNG

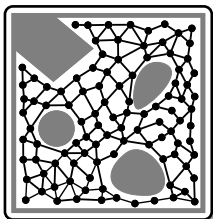

SGNG [Tencé et al., 2010b]

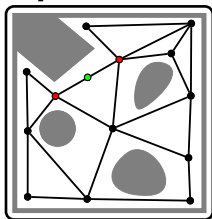

Résultats qualitatifs

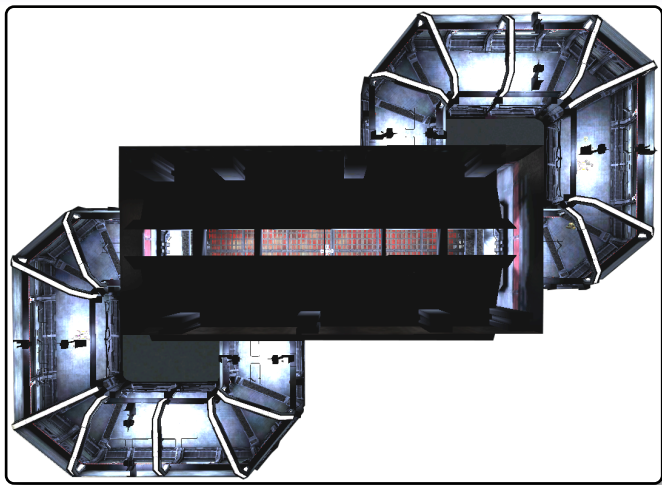

Résultats qualitatifs

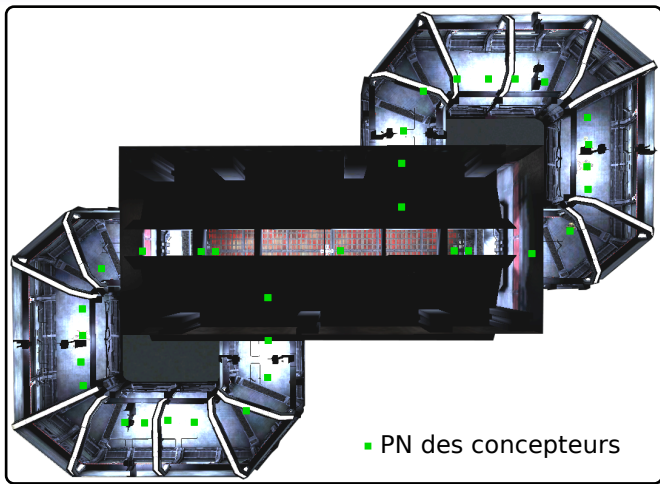

Résultats qualitatifs

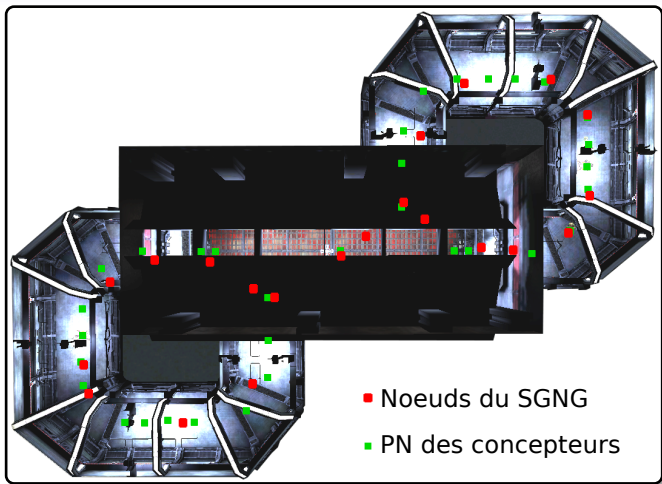

Résultats quantitatifs

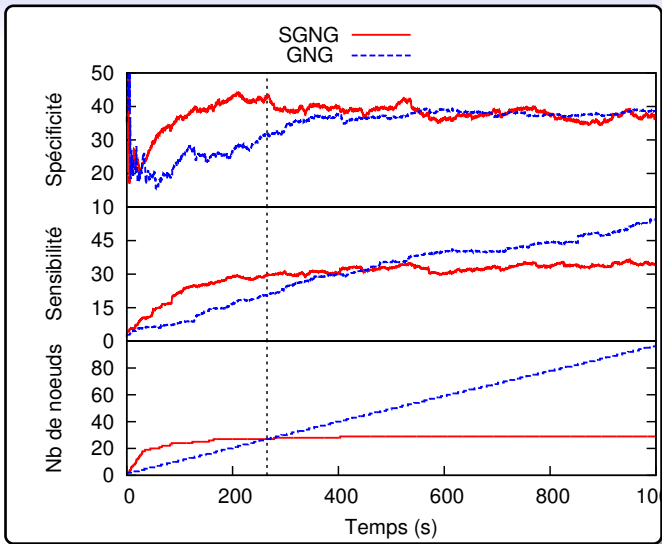
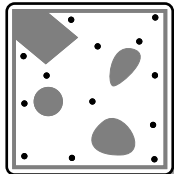
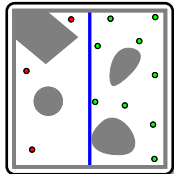
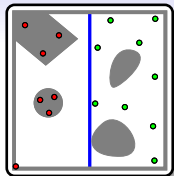

Plan

1 Introduction

2 État de l'art

3 Points de navigation

4 **Modèle de comportement**

- Fonctionnement
- Apprentissage

5 Conclusion

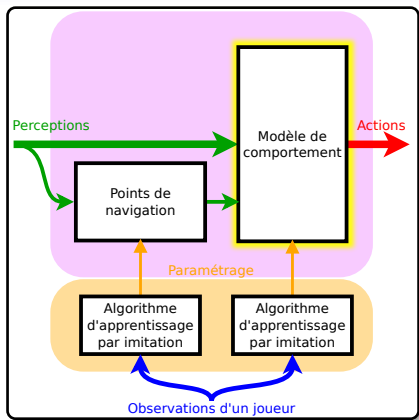

Variables aléatoires et dépendances

Objectif

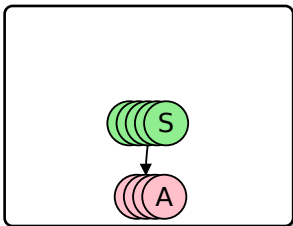

[Le Hy, 2007] IOHMM

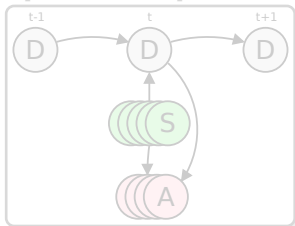

Explosion combinatoire

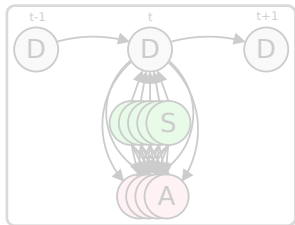

Variables aléatoires et dépendances

Objectif

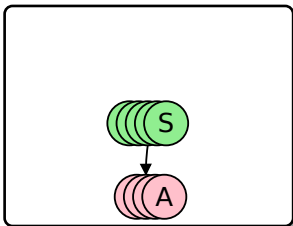

[Le Hy, 2007] IOHMM

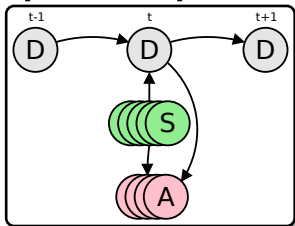

Explosion combinatoire

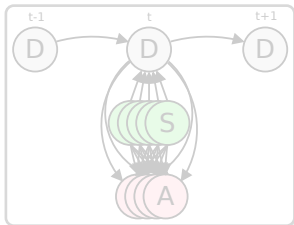

Variables aléatoires et dépendances

Objectif

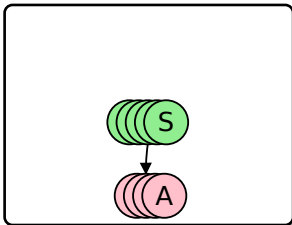

[Le Hy, 2007] IOHMM

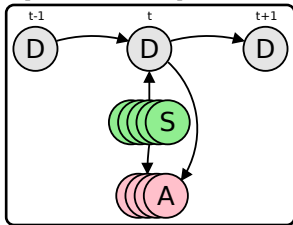

Explosion combinatoire

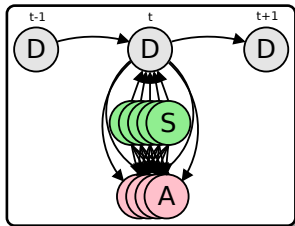

Raffinement sémantique

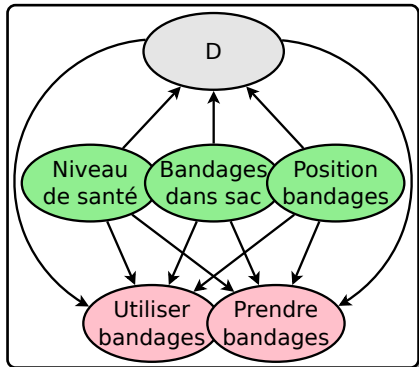
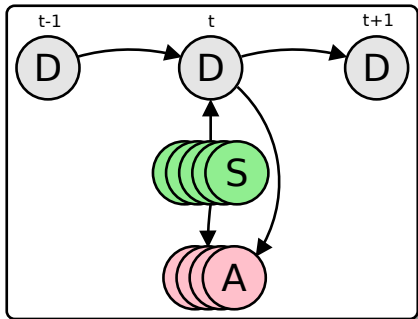

Raffinement sémantique

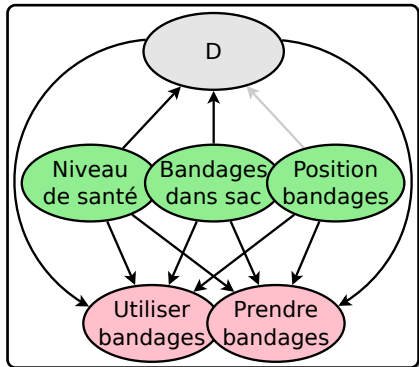
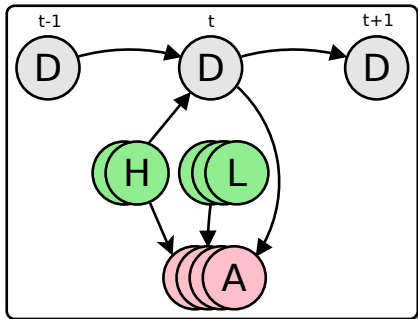

Raffinement sémantique

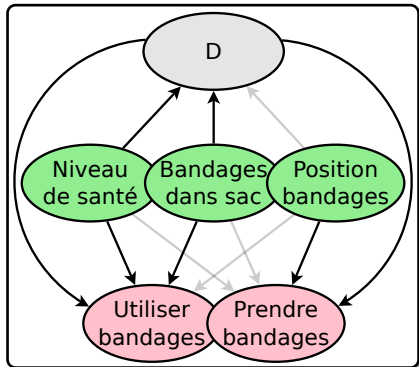
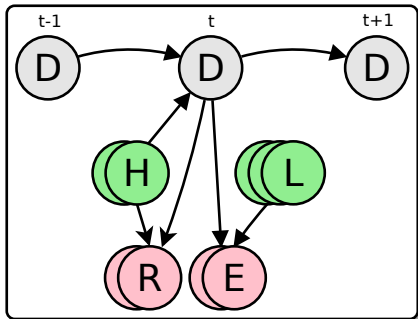

Mécanisme d'attention

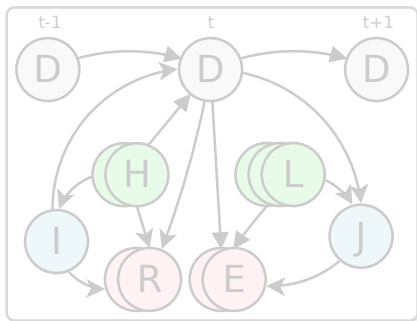
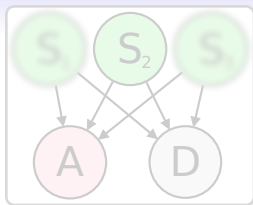
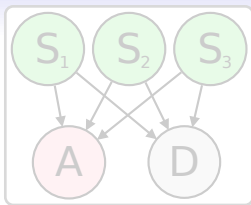
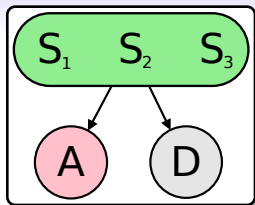

Mécanisme d'attention

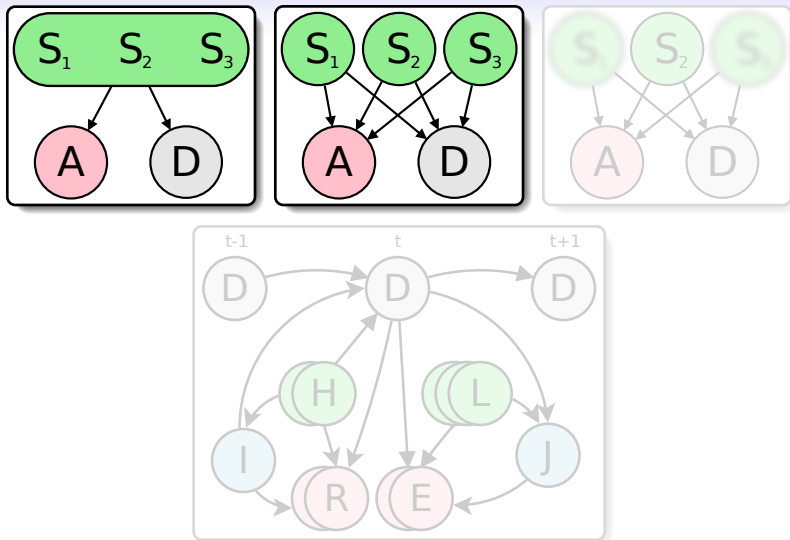

Mécanisme d'attention

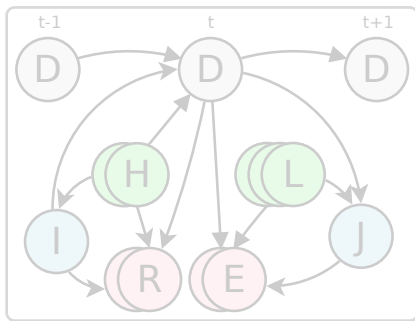
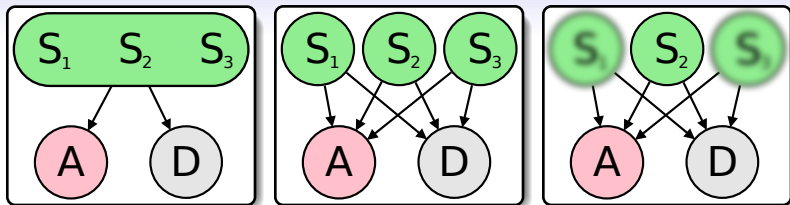

Mécanisme d'attention

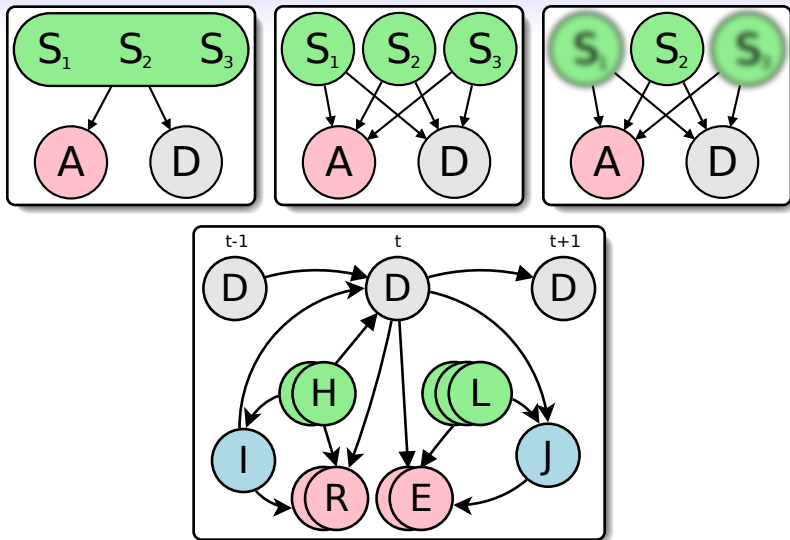

Résultats : nombre de paramètres

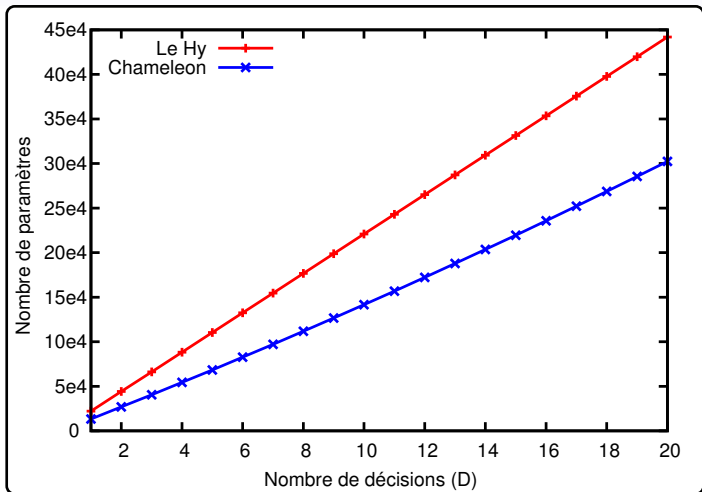

Résultats : comportement

Comportement : exploration

Le Hy

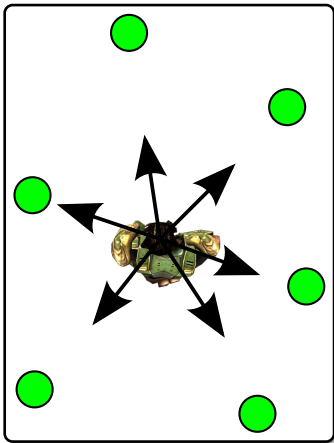

Attention

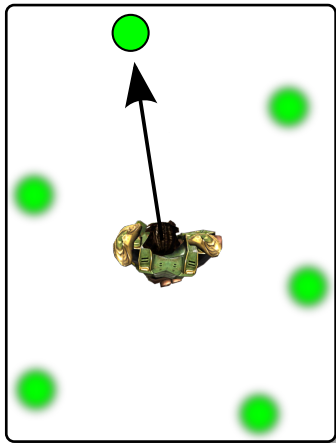

Plan

1 Introduction

2 État de l'art

3 Points de navigation

4 **Modèle de comportement**

- Fonctionnement
- Apprentissage

5 Conclusion

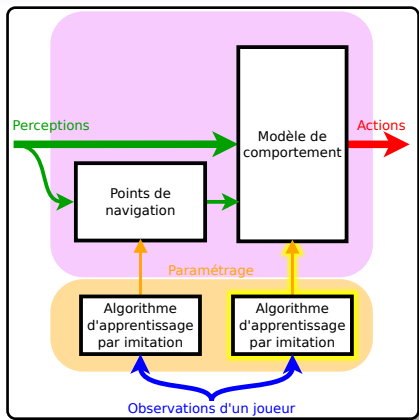

Apprentissage du comportement

Objectif

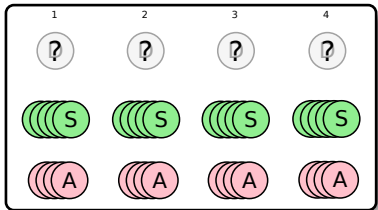

[Florez-Larrahondo, 2005]

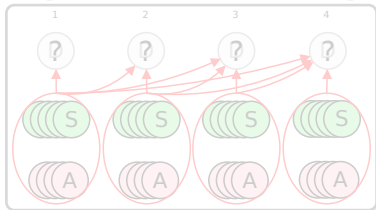

Seulement forward

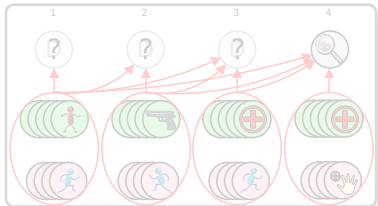

Application EM [Dempster et al., 1977]

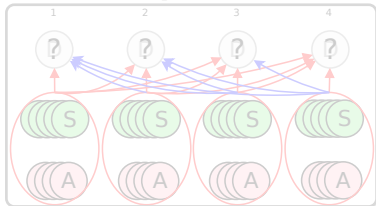

Apprentissage du comportement

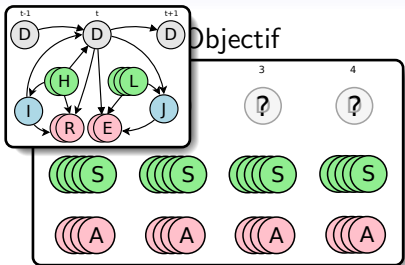

Objectif

[Florez-Larrahondo, 2005]

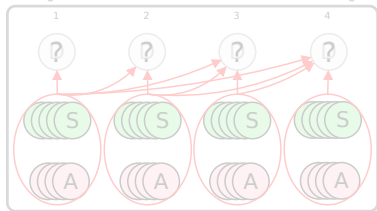

Seulement forward

Application EM [Dempster et al., 1977]

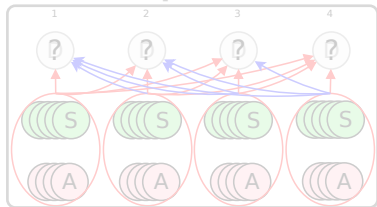
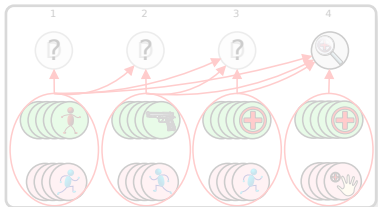

Apprentissage du comportement

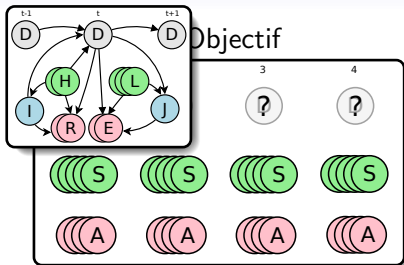

[Florez-Larrahondo, 2005]

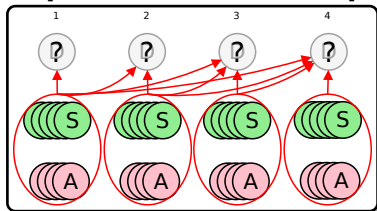

Seulement forward

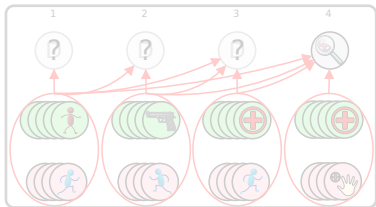

Application EM [Dempster et al., 1977]

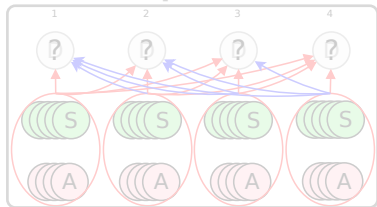

Apprentissage du comportement

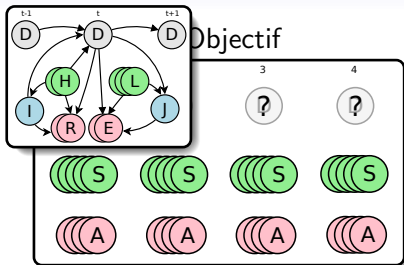

Seulement forward

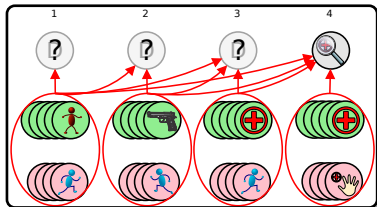

[Florez-Larrahondo, 2005]

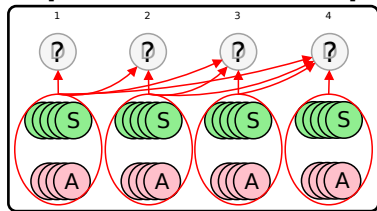

Application EM [Dempster et al., 1977]

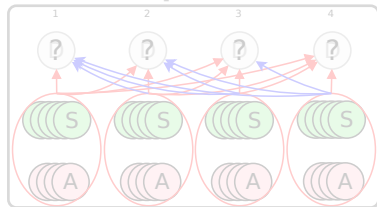

Apprentissage du comportement

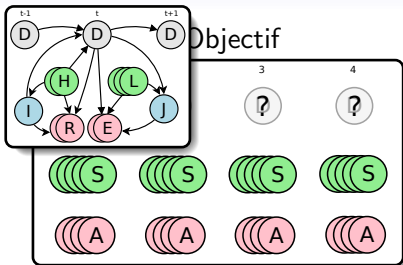

[Florez-Larrahondo, 2005]

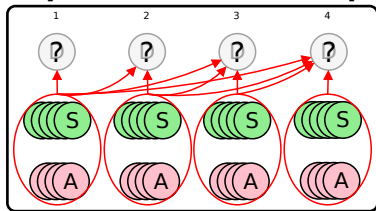

Seulement forward

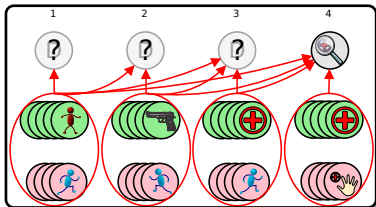

Application EM [Dempster et al., 1977]

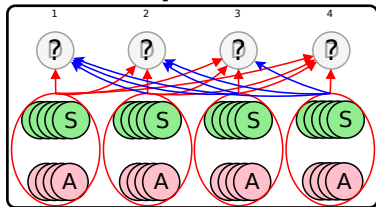

Log-vraisemblance et convergence

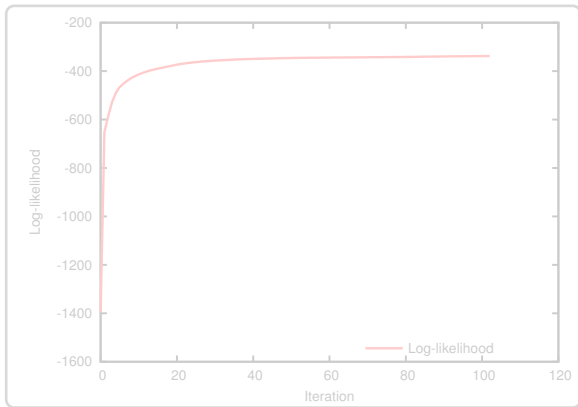
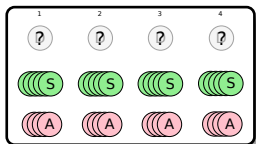
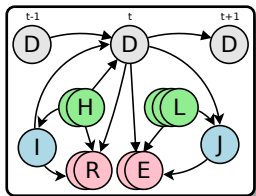

Log-vraisemblance et convergence

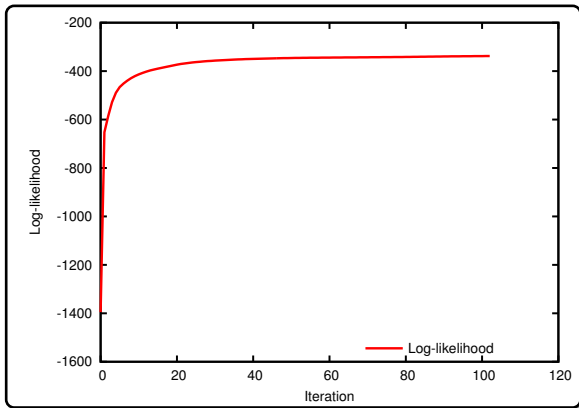
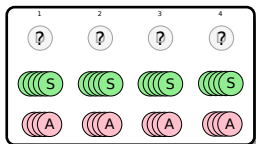
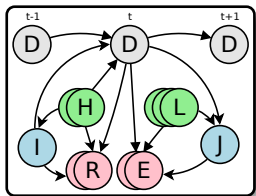

Temps de réaction et nombre de décisions

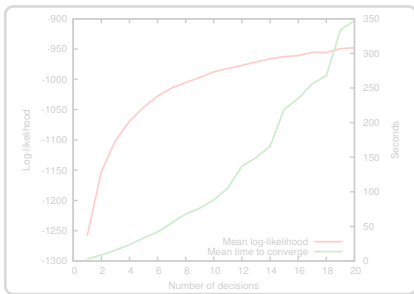
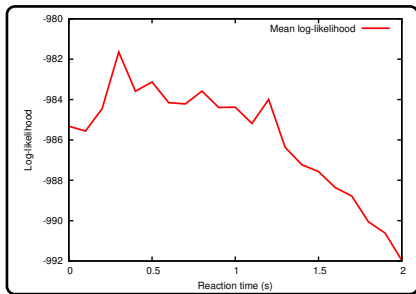
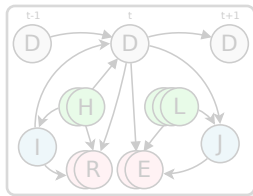
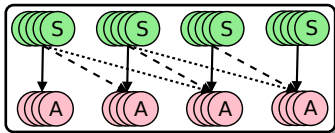

Temps de réaction et nombre de décisions

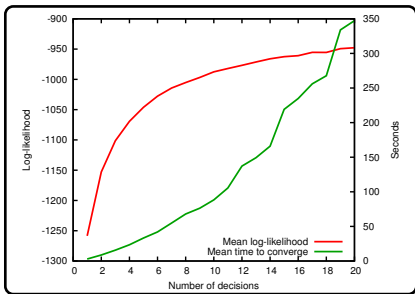
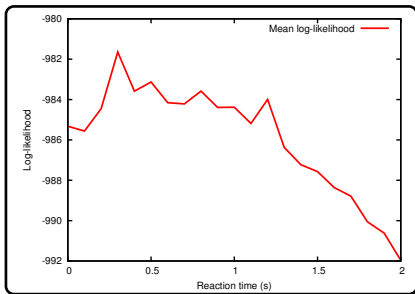
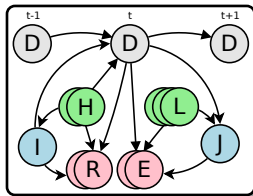
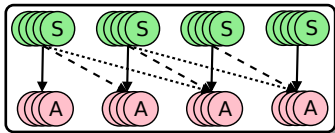

Résultats

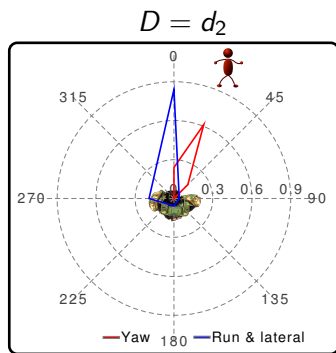
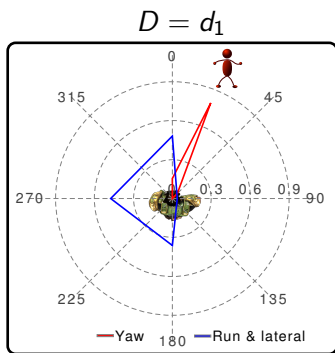

Plan

- 1 Introduction
- 2 État de l'art
- 3 Points de navigation
- 4 Modèle de comportement
- 5 Conclusion**

Chameleon

Objectifs

Crédibilité Imitation

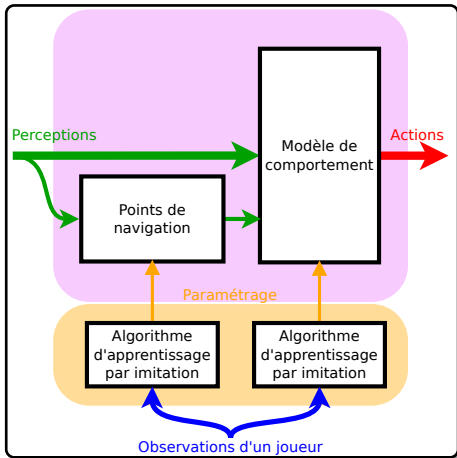

4 propositions

SGNG

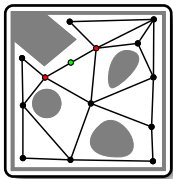

Raffinement

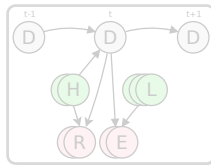

Attention

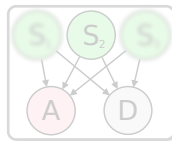

EM

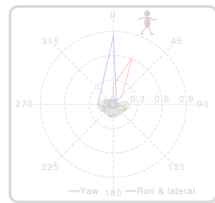
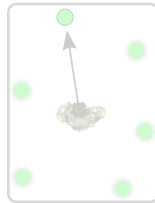
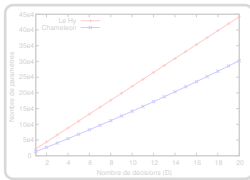
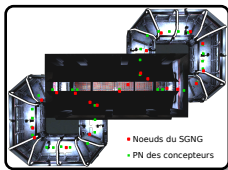
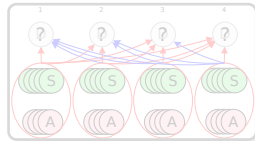

[Tencé and Buche, 2008, Tencé et al., 2010a, Tencé et al., 2010b]

4 propositions

SGNG

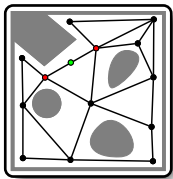

Raffinement

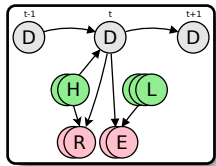

Attention

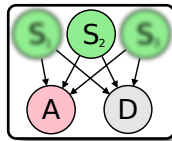

EM

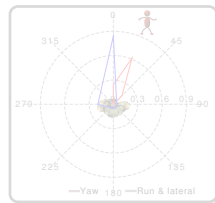
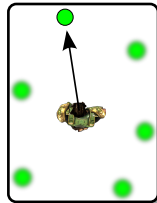
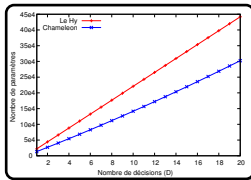
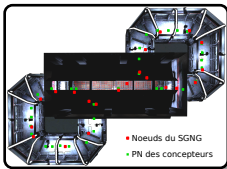
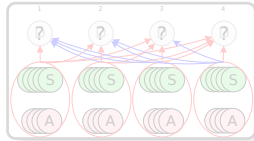

[Tencé and Buche, 2008, Tencé et al., 2010a, Tencé et al., 2010b]

4 propositions

SGNG

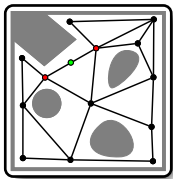

Raffinement

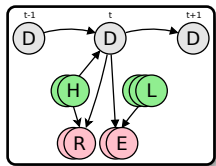

Attention

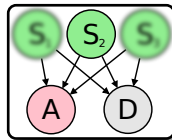

EM

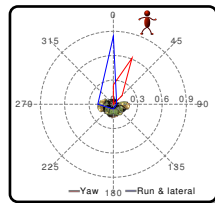
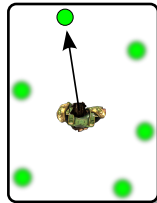
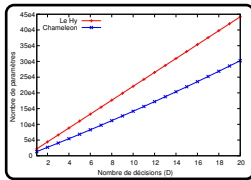
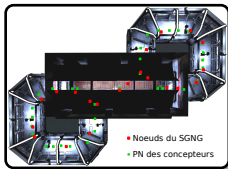
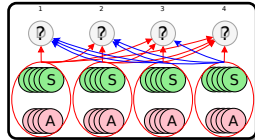

[Tencé and Buche, 2008, Tencé et al., 2010a, Tencé et al., 2010b]

Perspectives

Améliorations :

- Attention
- Apprentissage
- Entrées/Sorties

Validation :

- Évaluation de la crédibilité

Futurs travaux :

- Thèse Julien Soler
- Développements chez Virtualys

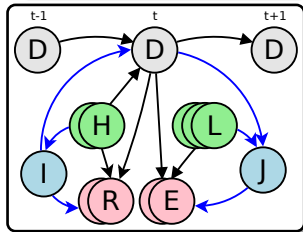
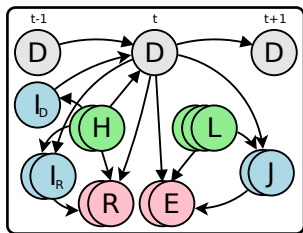

Perspectives

Améliorations :

- Attention
- Apprentissage
- Entrées/Sorties

Validation :

- Évaluation de la crédibilité

Futurs travaux :

- Thèse Julien Soler
- Développements chez Virtualys

Test 1 of 15: 3 Clips
Please fill in each of the required sections below, and then click the [Submit and Continue] button.



0:00 / 00:00

Please assess the clip on the right:

- Human
- Probably Human
- Don't Know
- Probably Artificial
- Artificial

Please explain your choice:

How many times did you view this clip, either in part or in full?

If you selected [Probably Artificial] or [Artificial], please indicate how humanlike you found this clip to be:

[Gorman et al., 2006]

Perspectives

Améliorations :

- Attention
- Apprentissage
- Entrées/Sorties

Validation :

- Évaluation de la crédibilité

Futurs travaux :

- Thèse Julien Soler
- Développements chez Virtualys



Modèle probabiliste de comportement et algorithme d'apprentissage par imitation pour les personnages crédibles dans les jeux vidéo

Fabien Tencé
Soutenance de thèse



10 novembre 2011



Dempster, A., Laird, N., and Rubin, D. (1977).

Maximum likelihood from incomplete data via the em algorithm.
Journal of the Royal Statistical Society. Series B (Methodological),
39(1) :1–38.



Florez-Larrahondo, G. (2005).

Incremental learning of discrete hidden Markov models.
PhD thesis, Mississippi State University.



Fritzke, B. (1995).

A growing neural gas network learns topologies.
In Advances in Neural Information Processing Systems 7, pages
625–632. MIT Press.



Gorman, B., Thureau, C., Bauckhage, C., and Humphrys, M. (2006).

Believability testing and bayesian imitation in interactive computer games.
In From Animals to Animats 9, volume 4095, pages 655–666.
Springer.



Le Hy, R. (2007).

Programmation et apprentissage bayésien de comportements pour des personnages synthétiques, application aux personnages de jeux vidéos.

PhD thesis, Institut national polytechnique de Grenoble.



Livingstone, D. (2006).

Turing's test and believable AI in games.

Computers in Entertainment, 4(1) :6.



Tencé, F. and Buche, C. (2008).

Automatable evaluation method oriented toward behaviour believability for video games.

In Vicente Botti, Antonio Barella, C. C., editor, *GAME-ON 2008 9th International Conference on Intelligent Games and Simulation*, pages 39–43. EUROSIS.



Tencé, F., Buche, C., De Loor, P., and Marc, O. (2010a).

The challenge of believability in video games : Definitions, agents models and imitation learning.

In Mao, W. and Vermeersch, L., editors, *GAMEON-ASIA'2010, 2nd Asian Conference on Simulation and AI in Computer Games*, pages 38–45. Eurosis.



Tencé, F., Buche, C., De Loor, P., and Marc, O. (2010b).

Learning a representation of a believable virtual character's environment with an imitation algorithm.

In Al-Akaidi, M., editor, *First annual Pan-Arabic International Conference on Intelligent Games and Simulation (GAMEON-ARABIA'10)*, pages 141–145. Eurosis.



Thureau, C., Bauckhage, C., and Sagerer, G. (2004).

Imitation learning at all levels of game-AI.

In *Proceedings of the International Conference on Computer Games, Artificial Intelligence, Design and Education*, pages 402–408.



Thurau, C., Paczian, T., and Bauckhage, C. (2005).

Is bayesian imitation learning the route to believable gamebots?

In *GAMEON-NA'2005*, pages 3–9.